

1. Planning the fence line

IMPORTANT: Ensure there are no underground services beneath the posts.

From packing list, check all parts are present. Start fence lines at gate positions or corners. Run taught string between pegs to define fence line. Mark the post positions required – not more than 2010mm (79") apart.

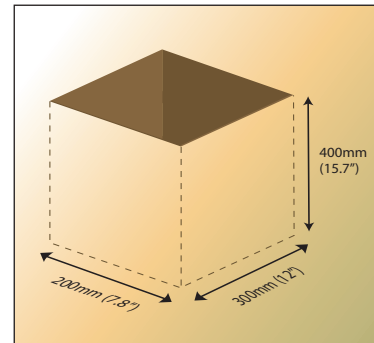

2. Digging the post hole

The unique post system does NOT require deep holes. Dig to achieve the minimum, but adequate, dimensions shown above. Or use a 250mm (9.9") auger to the same depth. It is not necessary to be square, but ensure the vertical sides are straight to avoid the possibility of underground frost forcing the concrete base up.

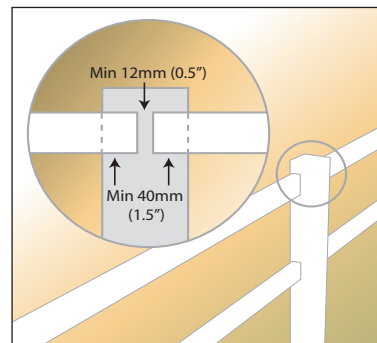

5. Fitting the rails

Slide each rail into post by at least 40mm (1.5") leaving a 12mm (0.5") gap – approx finger width – between rail ends for expansion and contraction. If necessary the rail may be cut using a conventional saw. For strength, 4m rails should be offset as per inset in diagram 6.

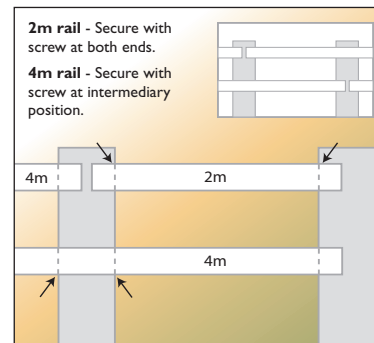

6. Securing the rails

Drill pilot holes in rails as shown above and fix with screws supplied. If rails are supplied with 'crimped' ends, screws are not required – simply push the rails into position. Fix caps with a pvc solvent adhesive ensuring even spread. Wipe off any excess.

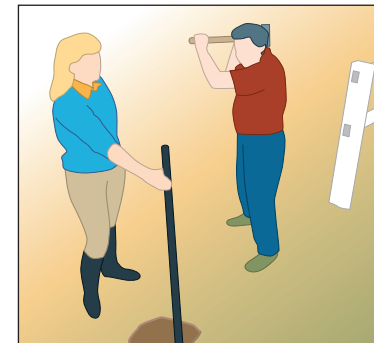

3. Installing the ground steel

Fill to 50mm (2") below ground level with a mix of 4 parts ballast/ 1 part cement. Lightly indent the position of the post on the wet cement. Place the steel in the indent created by the steel chamber (figure A). Drive half the steel length through the wet cement and into the ground. 50% of the steel should remain above ground.

IMPORTANT: At this stage check that the spikes are vertical and your measurements and line are correct.

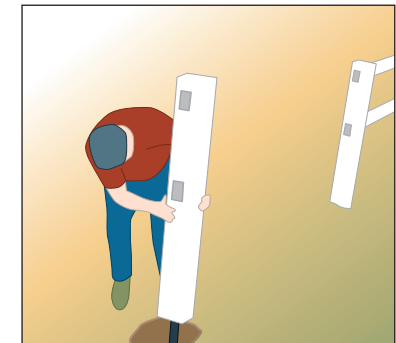

4. Installing the posts

Place steel chamber over the steel. Fill with concrete so that it just covers the steel – DO NOT fill to the top of the chamber. Ensure post is level and in line by raising and lowering the post. When the concrete has set – minimum 5 hours – replace the base area with turf or soil, or slope some concrete away from the post.

ADDITIONAL CONSIDERATIONS

Corner and T-posts

Before cementing a steel chamber which has rail holes, ensure rails are filled and ends are sealed with paper or tape.

Sloping Ground

Rails that span between single posts can be inclined up to 5 degrees. For steeper slopes carefully sand or file the rail holes to elongate them. File at the same angle as the rail to ensure an even fit. Rails should slide with light drag. 4m rails can be cut into two 2m lengths and fitted the same way.

Picket Fencing (including weldmesh or tubed panels)

Fit posts and rails as above. If pre-made panels are supplied, trim panel length to size (if required) and fit. Insert panel fully into left hand post, then insert into right hand post and centralize. Fix with screws.